

MSE200

Lecture 7 (CH. 6.2-6.4)

Mechanical Properties I

Instructor: Yuntian Zhu

•Objectives/outcomes: You will learn the following:

- Stresses and strains in solids.
- Normal and shear stresses.
- Elastic and plastic deformation.
- The tensile test and the engineering stress-strain curves.
- Young's modulus, the yield strength, the ultimate tensile strength, the percent elongation and percent reduction in area.
- True stress and true strain. Hardness and hardness testing

Elastic and Plastic Deformation in Metals

- **Elastic deformation: Metal returns to its original dimension after the force is removed.**
- **Plastic deformation: The metal is deformed to such an extent such that it cannot return to its original dimension after the load is removed**

Engineering Stress and Strain – under tension/compression

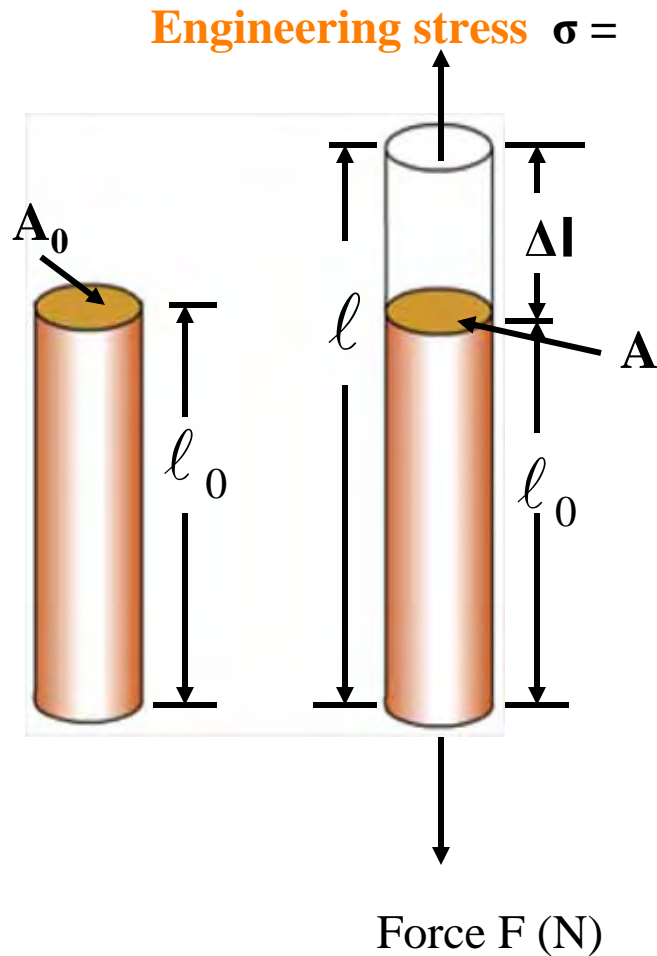

Units of Stress are N/m^2 (Pascals, or Pa) or PSI

Engineering strain = ϵ

$$= \frac{l - l_0}{l_0} = \frac{\Delta l}{l_0}$$

For elastic deformation: $\sigma = E \epsilon$

E is the Young's modulus

Poisons Ratio

Poisons ratio =
$$\nu = -\frac{\epsilon \text{ (lateral)}}{\epsilon \text{ (longitudinal)}} = -\frac{\epsilon_y}{\epsilon_z}$$

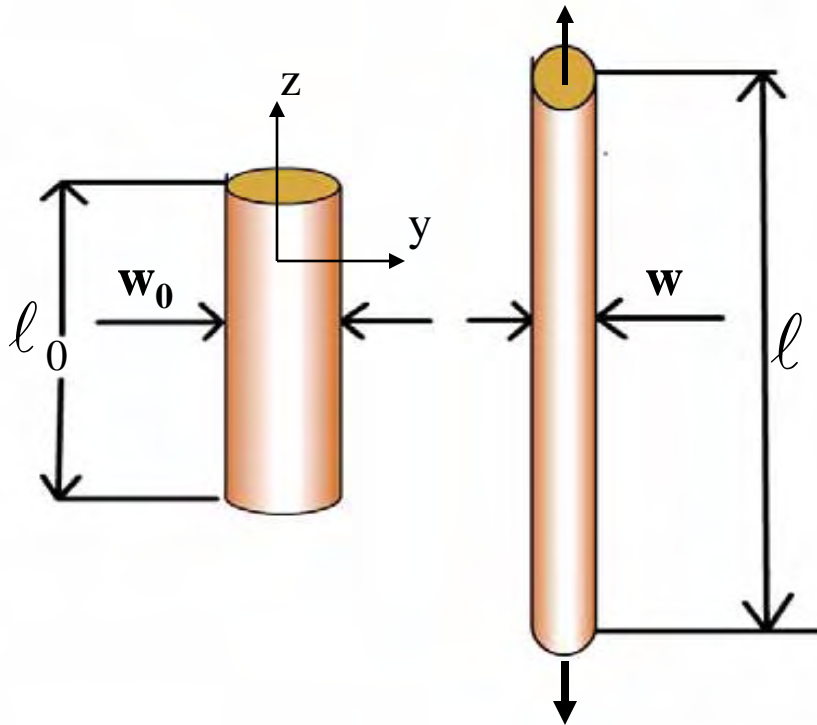

$$\nu = -\frac{w - w_0}{l - l_0}$$

Usually poisons ratio ranges from **0.25 to 0.4**.

Example: Stainless steel \rightarrow **0.28**
Copper \rightarrow **0.33**

Shear Stress and Shear Strain

S (Shear force)

Shear stress $\tau = \frac{S}{A}$ (Area of shear force application)

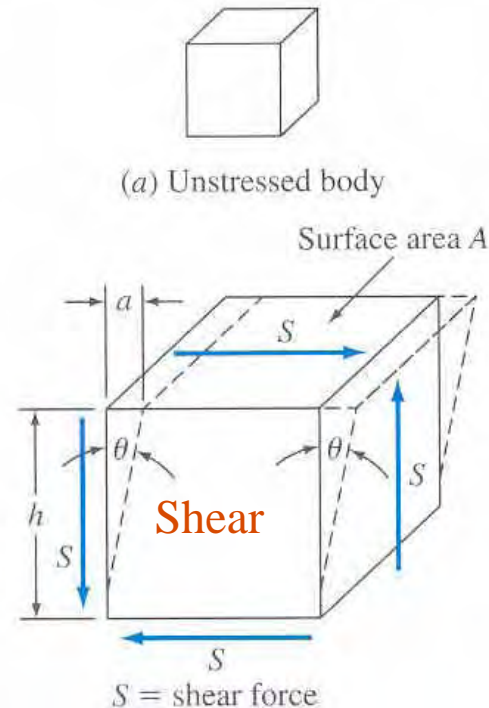
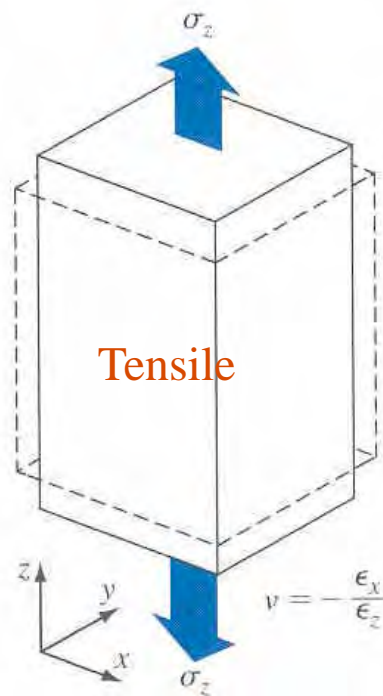

Shear strain $\gamma = \frac{\text{Amount of shear displacement}}{\text{Distance 'h' over which shear acts}}$

Shear Modulus $G = \tau / \gamma$

Tensile test/The most common test

- **Strength of materials can be tested by pulling the metal to failure.**

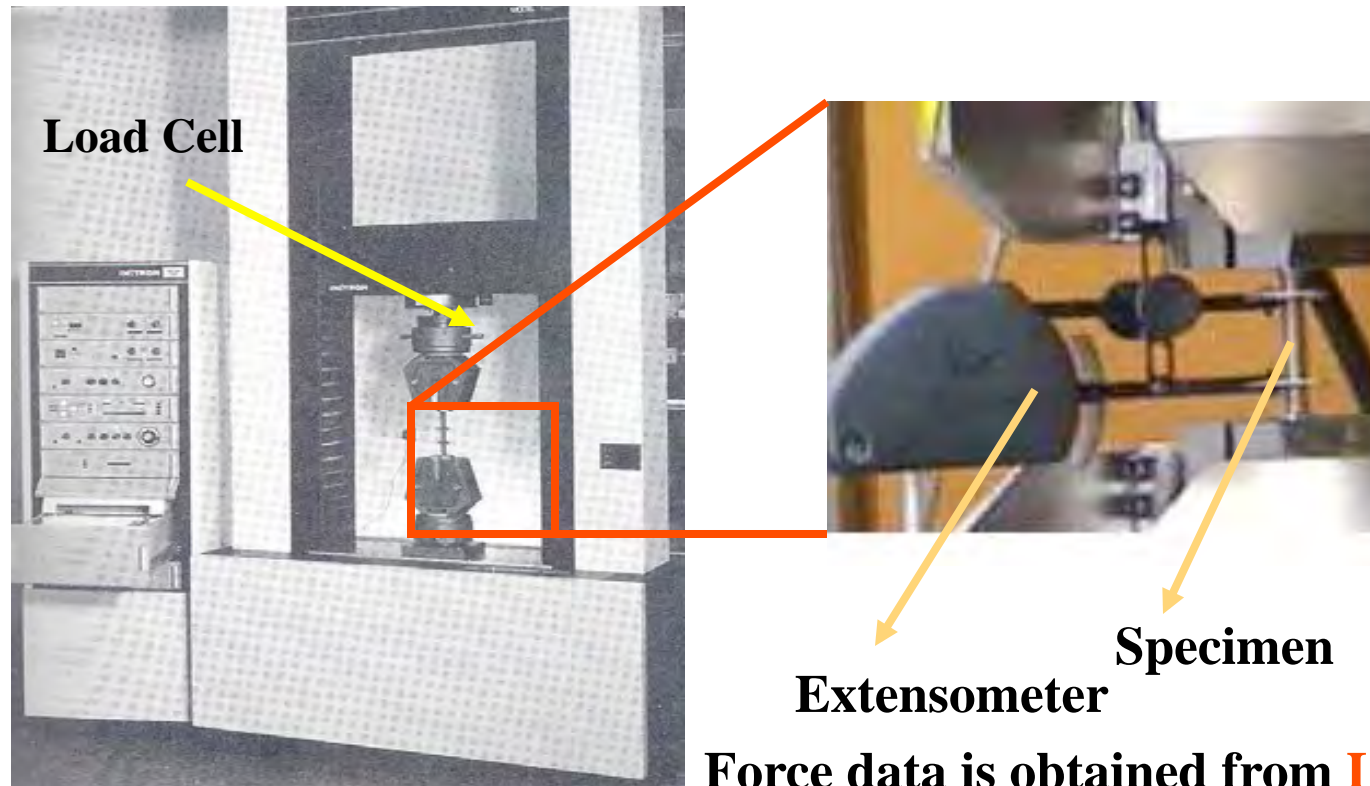

Force data is obtained from Load cell
Strain data is obtained from Extensometer.

<http://video.google.com/videosearch?q=tensile+testing&hl=en&emb=0&aq=0&oq=tensile+test#>

Tensile Test (Cont)

Round bar sample

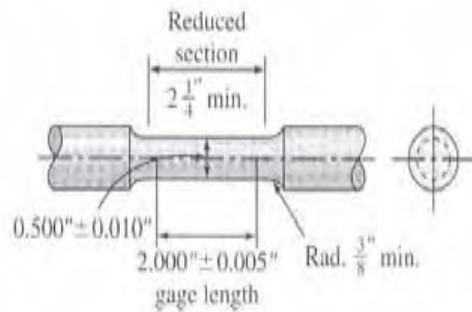

Flat sheet sample

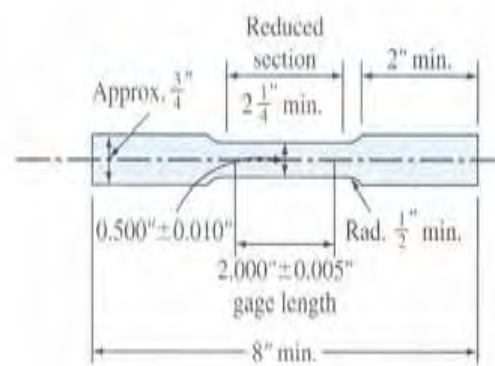
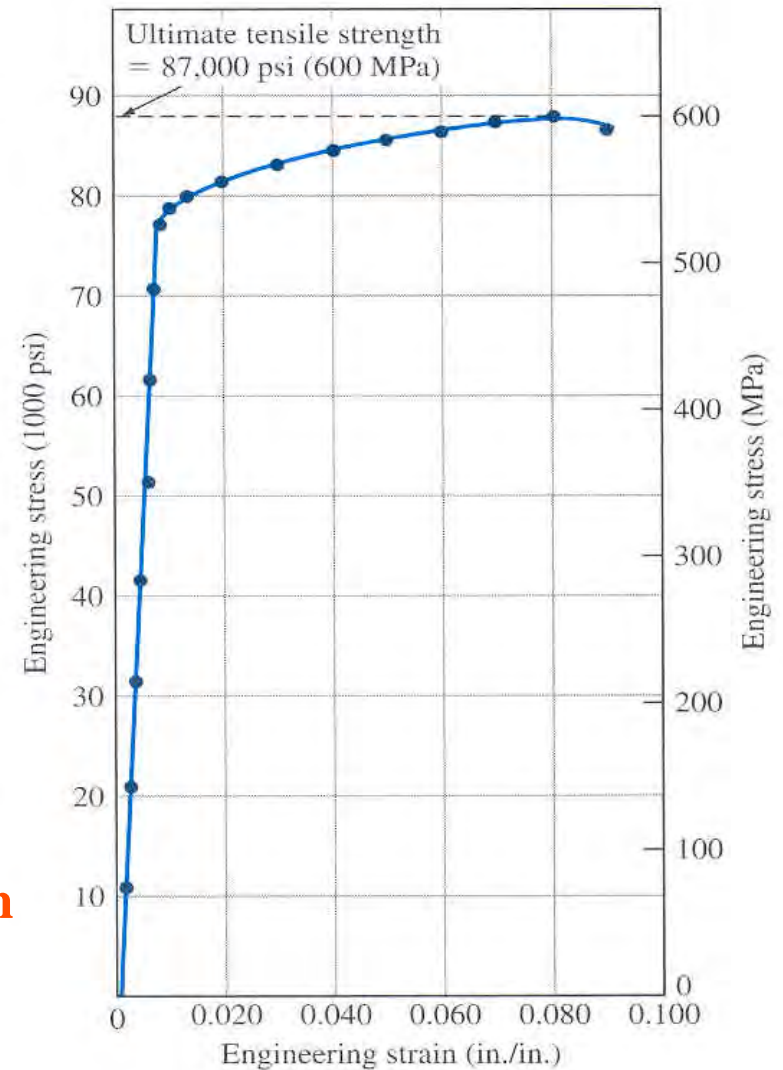

Figure 6.21

**Commonly used
Test specimen**

**ASTM standard gives
more information**

**Typical Stress-strain
curve**



Young's Modulus

- **Young's Modulus (E)** : Stress and strain are linearly related in elastic region. (Hooks law)

$$E =$$

Strain

Linear portion of the stress strain curve

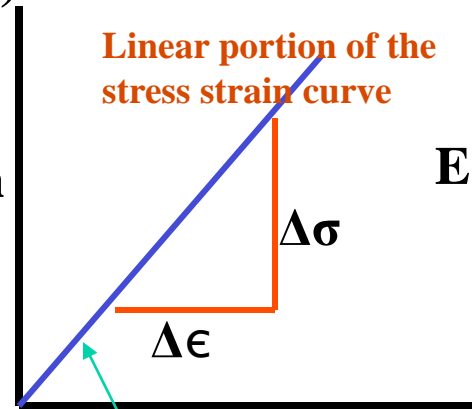

$$E = \frac{\Delta\sigma}{\Delta\epsilon}$$

- **Higher the bonding strength,**
higher is the modulus of elasticity
- **Largely determined by composition**
- **Insensitive to the grain size**

Stress

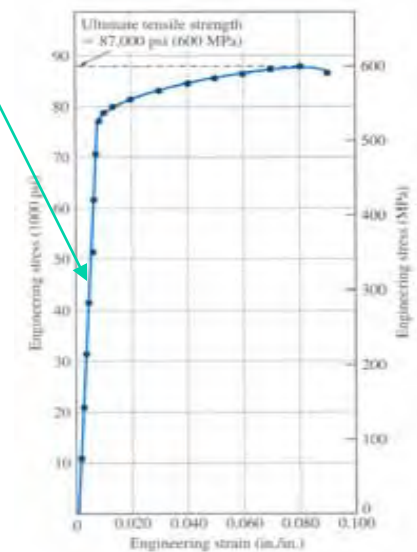

Yield Strength

- **0.2% offset yield strength** is that strength at which 0.2% plastic deformation takes place.
- Construction line, starting at 0.2% strain and parallel to elastic region is drawn to find 0.2% offset yield strength.

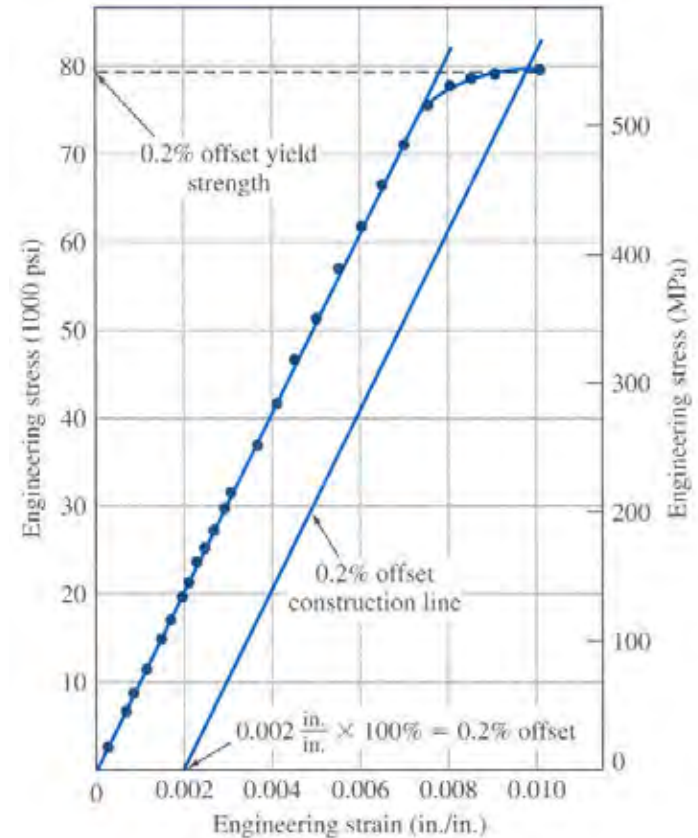

Ultimate tensile strength

- Ultimate tensile strength (UTS) is the maximum strength reached by the engineering stress strain curve.
- **Necking** starts after UTS is reached.



- More ductile the metal is, more is the necking before failure.
- **True stress level at necking section?**

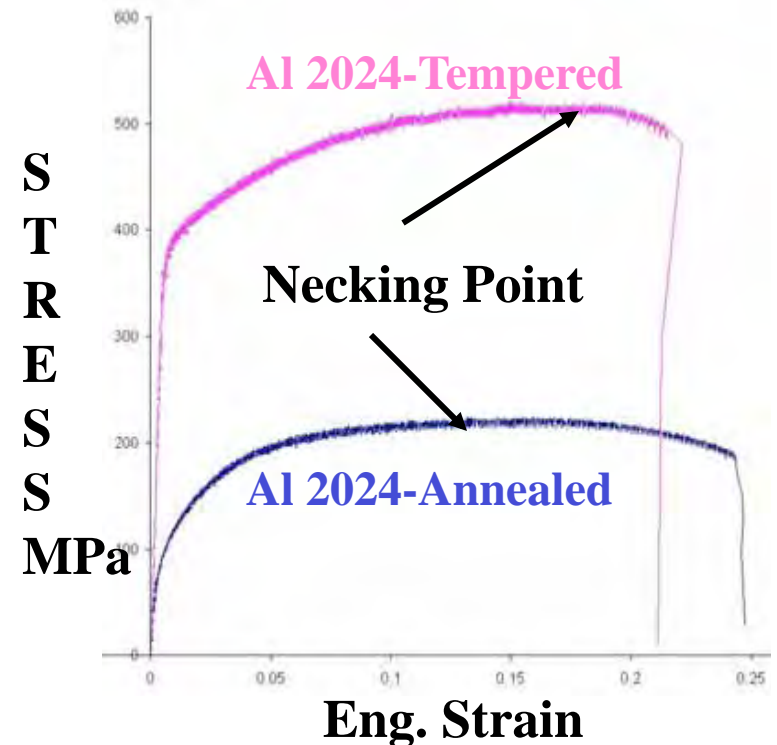

Engineering Stress strain curves of Al 2024 With two different heat treatments. Ductile annealed sample necks more

Percent Elongation/Ductility

- Percent elongation (**elongation to failure**) is a measure of **ductility** of a material.
- It is the elongation of the metal before fracture expressed as **percentage of original length**.

% Elongation to failure =

i.e. Ductility (ϵ_f) =
$$\frac{l_f - l_0}{l_0}$$

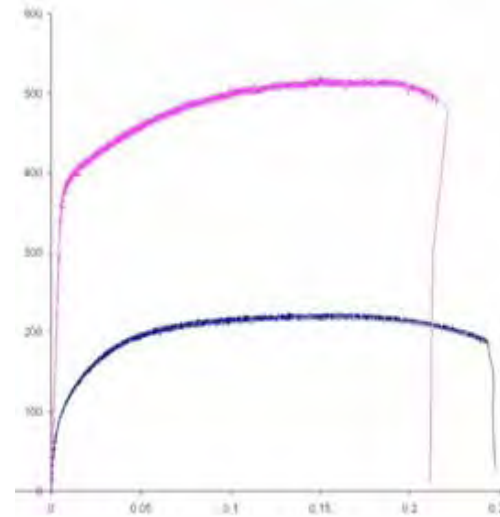

Percent Reduction in Area

- **Percent reduction area** is also a measure of **ductility**.

$$\% \text{ Reduction Area} = \frac{\text{Initial area} - \text{Final area}}{\text{Final area}}$$

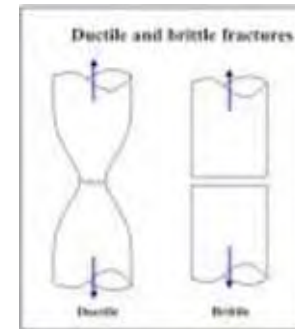

Ductile Brittle

- **Percent reduction in area** in metals decreases in case of **presence of porosity**.

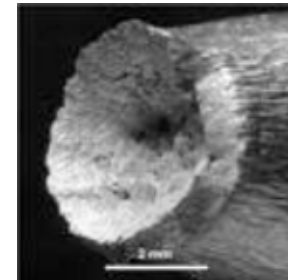

True Stress – True Strain

- True stress and true strain are based upon **instantaneous** cross-sectional area and length.

F

- True Stress = $\sigma_t = \frac{F}{A_i \text{ (instantaneous area)}}$

- True Strain = $\epsilon_t = \ln \frac{l_i}{l_0} = \ln \frac{A_0}{A_i}$

$$\sigma_t = \sigma (1 + \epsilon)$$

$$\epsilon_t = \ln (1 + \epsilon)$$

Hardness and Hardness Testing

- **Hardness is a measure of the resistance of a metal to **permanent** (plastic) deformation.**
- **General procedure:**

Press the indenter that is harder than the metal into metal surface.

Withdraw the indenter

Measure hardness by measuring depth or width of indentation.

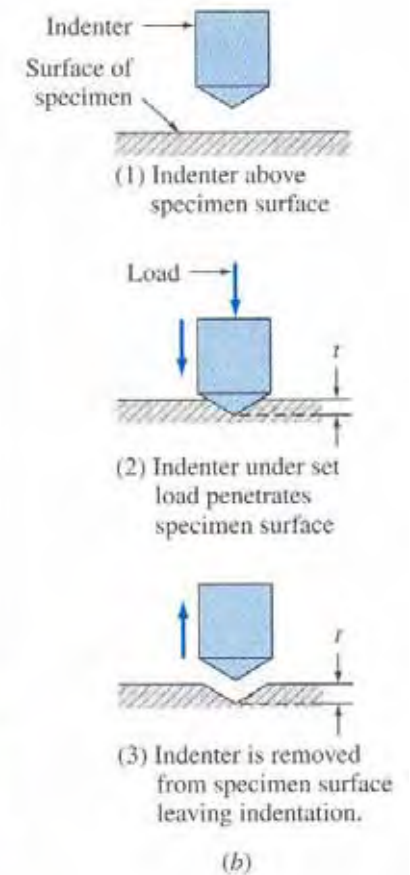

Home work

- Example Problems: 6.4, 6.5, 6.6, 6.7, 6.8,
- Regular Problems, Chapter 6: 18, 19, 23, 24, 25, 29, 30,
- Reading assignment: section 6.5-6.8